

KINNEY®

Liquid Ring Vacuum Pumps

Kinney® KLRC & A Series



Kinney | www.kinneyvacuum.com | (800) 825-6937

Liquid Ring Vacuum Systems & Packages

AERC (Air Ejector/Liquid Ring System)

- KLRC Series two-stage vacuum pump
- Capacity range: 30-550 CFM
- Blank-off vacuum down to 3 Torr

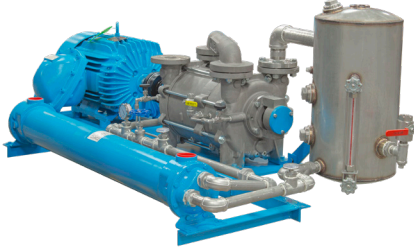

Multistage Vacuum System with Vacuum Boosters

- Capacity:
100-10,000 CFM
(170-17,000 M3/Hr)
- Maximum vacuum:
29.92" Hg Vac
(0.01 mmHg Absolute)



LRC (Liquid Ring Compressors - Model AC)

- A Series single-stage compressor
- Capacity range: 15-275 SCFM
- Discharge pressure up to 20 PSIG



OSR (Oil Sealed Recirculation Package)

- A Series single-stage vacuum pump
- Capacity range: 15-300 CFM
- Blank-off vacuum down to 10 Torr
- Air-cooled version

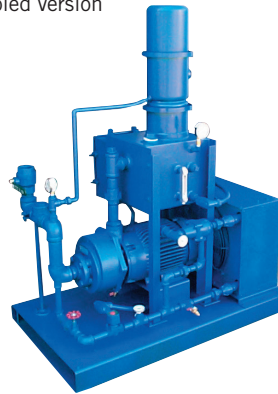

EOP (Environmental Remediation Package - Oil Sealed)

- A Series single-stage vacuum pump
- Capacity range: 10-300 CFM
- Water-sealed package available EWP
- Explosion proof packages available
- Blank-off vacuum down to 10 Torr



CVP (Central Vacuum Package)

- A Series single-stage vacuum pump
- Capacity range: 10-300 SCFM
- Water-sealed or oil-sealed

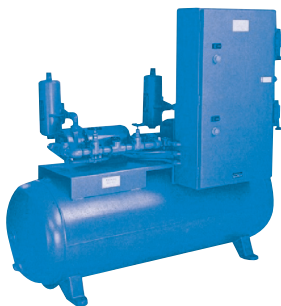

DRSP (Deluxe Ring Simplex Package) DRDP (Deluxe Ring Duplex Package)

- KLRC Series two-stage vacuum pump
- Capacity range: 75-950 CFM
- Water-sealed or oil-sealed



ACRP (Air Cooled Oil/Glycol Sealed Recirculation Package)

- KLRC Series two-stage vacuum pump
- Higher capacity at deeper vacuum than water-sealed
- Capacity range: 75-950 CFM
- Blank-off vacuum down to 10 Torr
- Water-cooled version: OFRP



Additional Packages and Engineered Solutions Available

The KLRC is a non-pulsating vacuum pump designed to remove gases through the use of rotating impeller blades that enter and leave a ring of liquid. The impeller forces this sealing liquid to the periphery of the pump casing where it forms a moving ring of liquid around a center void.

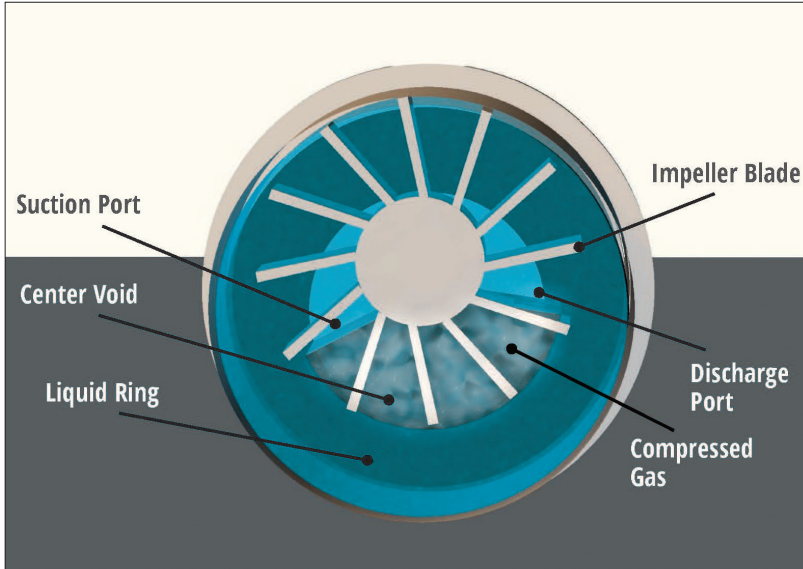

The impeller shaft is mounted above the centerline of the casing while the blades, although rotating concentrically, are located eccentrically with respect to the casing and the ring of liquid. The pump's axial suction and discharge ports are exposed to the void but separated by the impeller blades and the ring of liquid. As the process gas or vapor is drawn into the pump through the suction port, it is trapped between the impeller blades and the liquid ring. The rotating blades enter deeper into the liquid ring progressively reducing the entrapment space, compressing and then exhausting the gas through the discharge port. The liquid ring acts like a liquid piston, meaning the entire pumping operation is accomplished without vanes, valves, pistons or any metal-to-metal contact.

Cast-in index marks for convenience in re-assembly

Shim size stamped on bearing housing for smooth re-assembly

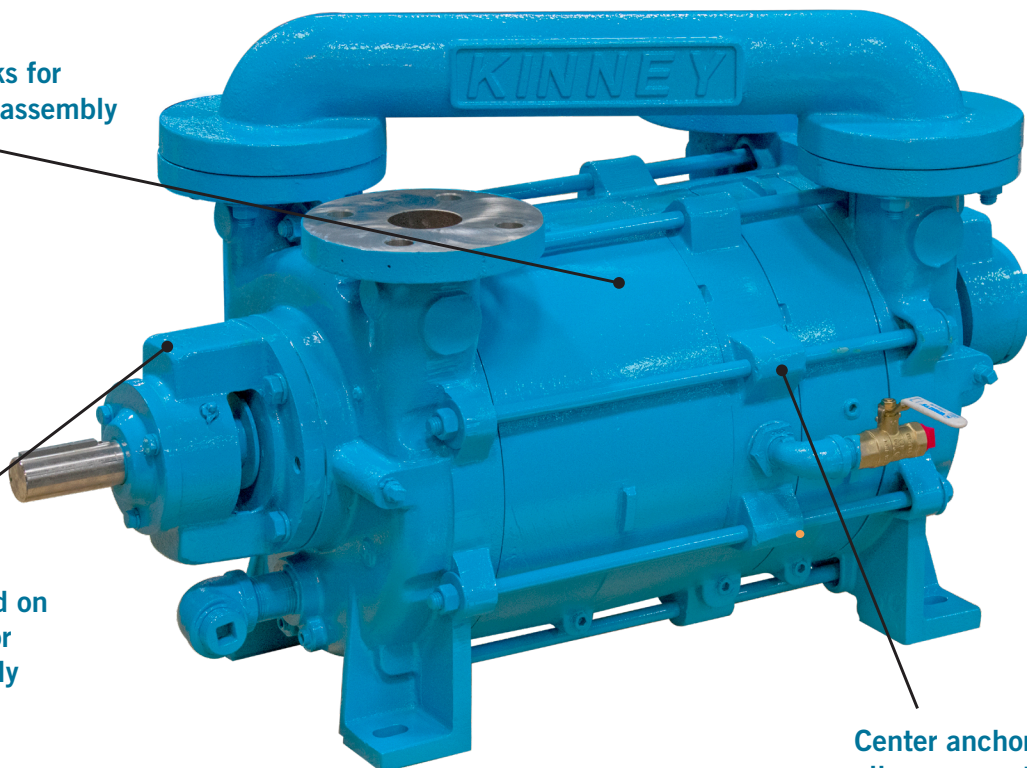

Center anchored tie bolts allow access to either end of the pump without total disassembly

Design | KLRC Series

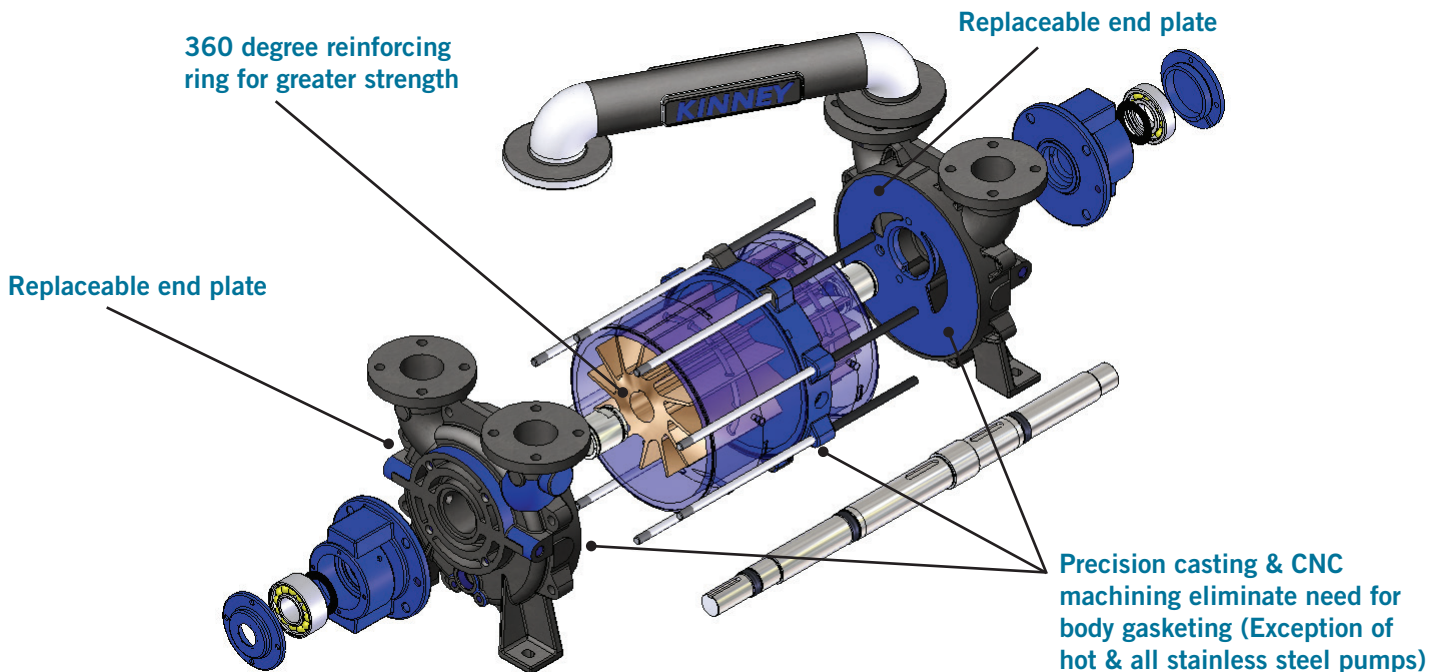

- Impellers axially locked to shaft to maintain clearances at both ends, meaning no shaft sleeve or spacer to machine
- Clearance maintained by bearing spacers, makes easy and quick re-assembly

Material of Construction

- Cast iron casings SS316L impellers SS316 shaft
- SS316L casings SS316L impellers SS316 shaft

Mechanical Shaft Seal

- Type 21 with Viton® or EPR elastomer
- Self compensate with standard and optional Viton®/EPR/Teflon® encapsulated or Kalrez™ O-Ring
- Double mechanical shaft seals for API plan 53

Double mechanical seal with barrier fluid and API plan 53 seal pot system

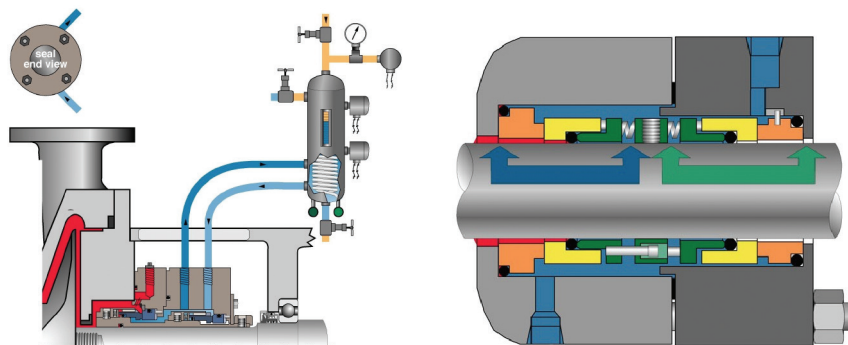

Specifications | KLRC Series

Performance

Inch Hg				22	24	26	27	28	28.5	28.8	
Torr				200	150	100	70	50	40	30	
KLRC	Flange Conn.	HP KW	RPM	CFM/M ³ /Hr	CFM/M ³ /Hr	CFM/M ³ /Hr	CFM/M ³ /Hr	CFM/M ³ /Hr	CFM/M ³ /Hr	CFM/M ³ /Hr	Seal Fluid Required (GPM)
75	1.5" x 1.5"	5 4	1750 1450	71 99	73 102	75 105	75 105	71 99	66 92	55 77	5
125	1.5" x 1.5"	10 7.5	1750 1450	139 195	141 199	140 197	135 192	124 175	111 156	90 127	7
200	2" x 2"	15 11	1750 1450	170 244	180 263	186 263	178 252	164 233	148 209	110 155	8
300	2" x 2"	25 18.5	1750 1450	305 432	302 425	295 417	274 387	250 353	225 315	185 262	12
525	3" x 3"	50 37	1750 1450	550 779	545 772	522 739	485 687	420 595	380 538	300 425	18
526	3" x 3"	40 30	1450	435 740	440 748	425 723	390 663	340 578	300 510	240 408	18
950	4" x 4"	100 75	1150	875 1488	920 1564	1020 1734	1060 1802	1030 1751	970 1649	825 1403	26
951	4" x 4"	60 45	880 960	790/1343 790/1343	825/1403 840/1428	825/1403 925/1572	790/1343 960/1632	675/1148 900/1530	550/935 880/1496	365/621 760/1292	26

Above performance data based on 68°F inlet air with 50% relative humidity and using water as a sealant at 60°F. Please refer to curve for correction factor (CF) to correct capacity if using water other than 60°F.

Dimensions

	KLRC 75		KLRC 125		KLRC 200		KLRC 300		KLRC 525-526*		KLRC 950-951*	
	in	mm	in	mm	in	mm	in	mm	in	mm	in	mm
A	24.13	613	28.06	713	29.69	754	33.56	852	41	1041	61.81	1570
B	11.88	302	12.75	324	16.88	429	16.88	429	18.88	479	----	----
C	----	----	16	406	19.13	486	19.13	486	23.5	597	32.88	822
D	11.19	284	13.13	333	12.38	314	16.31	414	22	559	31.25	794
E	12.63	321	13	330	15.25	387	15.25	387	18.56	471	23.5	597
F	14.69	373	17.88	454	16.94	430	20.88	530	27.38	695	37.38	949
G	10	254	10.63	270	11.75	298	11.75	298	15.75	400	18.88	480
H	6.5	165	8.25	175	8.25	232	8.25	232	9.81	243	12.63	321
lbs	200		255		360		405		800		1529	

Consult factory for detailed drawings. *KLRC 525/950 can also be belt driven with the model number of KLRC 526/951.

Sealing Inlet Connections

KLRC 75	KLRC 125	KLRC 200	KLRC 300	KLRC 525-526	KLRC 950-951
1/2" NPT	3/4" NPT	1" NPT	1" NPT	1-1/4" NPT	1-1/2" NPT

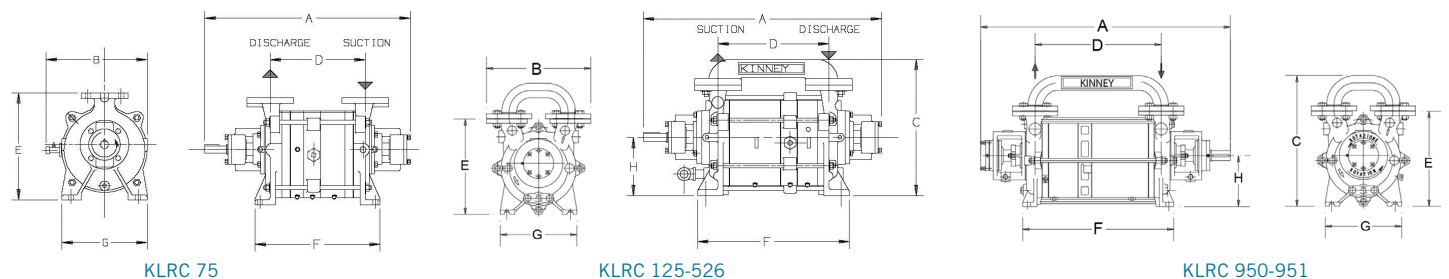

Design | A Series

A Series vacuum pumps consist of a shrouded motor rotating freely within an eccentric casing. Centrifugal force acting on liquid with the pump causes the liquid to form a ring inside the casing. A fixed port cylinder, concentric with the rotor, directs the gas into the suction ports. Gas is trapped between the blades by the liquid pistons formed by centrifugal force as the liquid recedes from the port cylinder. It is trapped at the point of maximum eccentricity and is then compressed by the liquid ring as it is forced radially inward toward the central port cylinder. After each revolution the compressed gas and accompanying liquid are discharged.

During the pumping cycle, the gas is in intimate contact with the sealing liquid and compression is nearly isothermal. When handling saturated vapor-gas mixtures, the liquid ring acts as a condenser, greatly increasing the effective capacity of the pump.



A Series motor-mounted single-stage liquid ring vacuum pump

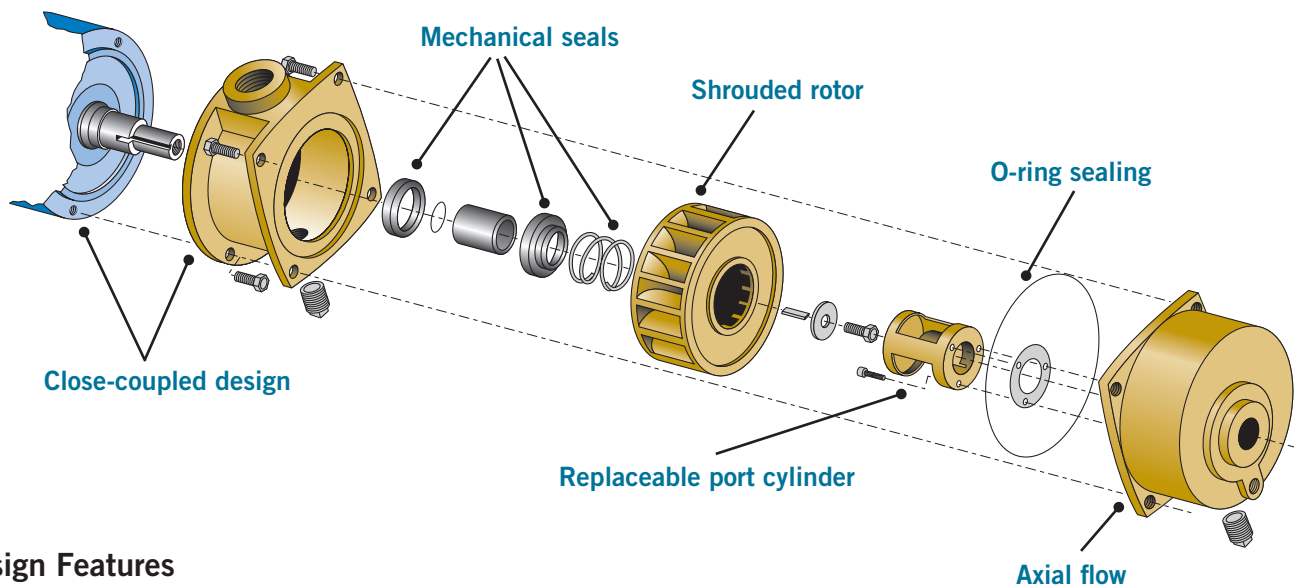

Design Features

- Flat power curve over entire vacuum range prevents motor overload
- Reduced stress on motor shaft and bearings
- Increased water handling capability prevents heat build-up; extends life of mechanical seals
- Compact, close-coupled design eliminates need for interstate manifold or motor alignment

The velocity of water through the pump is virtually constant and carries the air out effortlessly, greatly reducing cavitation compared to older flat plate designs.

Specifications | A Series

Performance

Inch Hg			15	20	25	27	28	
Torr			380	250	125	75	50	
Model	HP KW	RPM	CFM/M ³ /Hr	CFM/M ³ /Hr	CFM/M ³ /Hr	CFM/M ³ /Hr	CFM/M ³ /Hr	Seal Fluid Required (GPM)*
A5	1 0.75	3450 2850	10 15	10 15	10 15	9 13	5 7	1.5
A10	1.5 1.1	3450 2850	15 21	15 21	15 21	13 18	10 14	1.5
A15	2 1.5	3450 2850	22 32	21 30	20 29	17 25	12 17	2
A20	3 2.2	3450 2850	34 47	35 49	32 44	27 38	19 27	2
A75	5 3.7	1750 1450	75 105	80 112	75 105	70 98	50 70	2.5
A100	7.5 5.5	1750 1450	110 154	115 163	105 148	90 127	58 81	2.5
A130	10 7.5	1750 1450	140 197	130 183	120 170	105 147	64 90	3
A200	15 9.3	1150 960	205 289	200 282	180 255	150 212	100 141	5
A300	20 15	1150 960	295 416	280 396	225 317	200 282	180 254	6

*GPM designates to operate up to 25" Hg vacuum. For deeper vacuum, higher flow required; please refer to maintenance manual. Above performance data based on 68oF inlet air with 50% relative humidity and using water as a sealant at 60oF. Please refer to curve for correction factor (CF) to correct capacity if using water other than 60oF.

A Series Liquid Ring Compressors

Capacity in SCFM

Model	HP	RPM	5 PSIG	10 PSIG	15 PSIG	20 PSIG
AC10	2	3500	15	14	12	7
AC15	3	3500	22	20	17	13
AC20	5	3500	30	27	23	19
AC75	7.5	1750	70	65	55	62
AC100	10	1750	100	95	80	62
AC130	15	1750	130	120	105	80
AC200	20	1150	225	210	180	145
AC300	25	1150	275	255	225	175

Material of Construction

A5	All Bronze
A10-A130	CI-Bronze/All Bronze/ CI-Stainless Steel/Stainless Steel
A200-A300	All Iron

All pumps are available in pedestal version except model A5.



Specifications | A Series

Close-Coupled Design

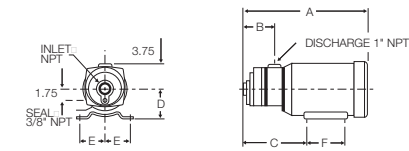

Model	FRAME	INLET	A	B	C	D	E	F	MOTOR HP	WEIGHT lbs/kg
A5	56CZ	3/4	14.0	2.9	6.7	3.5	2.44	3.0	1	45/20
A10	145TCZ	1	16.6	3.6	8.0	3.5	2.75	5.0	1 1/2	55/25
A15	145TCZ	1	17.0	3.8	8.3	3.5	2.75	5.0	2	60/27
A20	182CZ	1	18.5	4.6	9.6	4.5	3.75	5.5	3	80/36

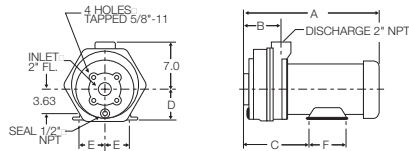

Model	FRAME	INLET	A	B	C	D	E	F	MOTOR HP	WEIGHT lbs/kg
A75	184TCZ	2	20.2	5.8	9.8	4.5	3.75	5.5	5	180/82
A100	213TCZ	2	23.1	7.1	12.1	5.25	4.25	7.0	7 1/2	195/89
A130	215TCZ	2	25.3	8.1	13.1	5.25	4.25	7.0	10	250/114

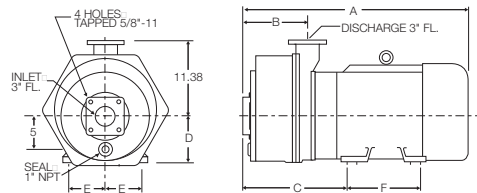

Model	FRAME	INLET	A	B	C	D	E	F	MOTOR HP	WEIGHT lbs/kg
A200	284TYZ	3	32.4	8.3	14.2	7.0	5.5	11.0	15	560/254
A300	284TYZ	3	33.7	9.7	15.6	7.0	5.5	11.0	20	600/272

Pedestal Mount Design

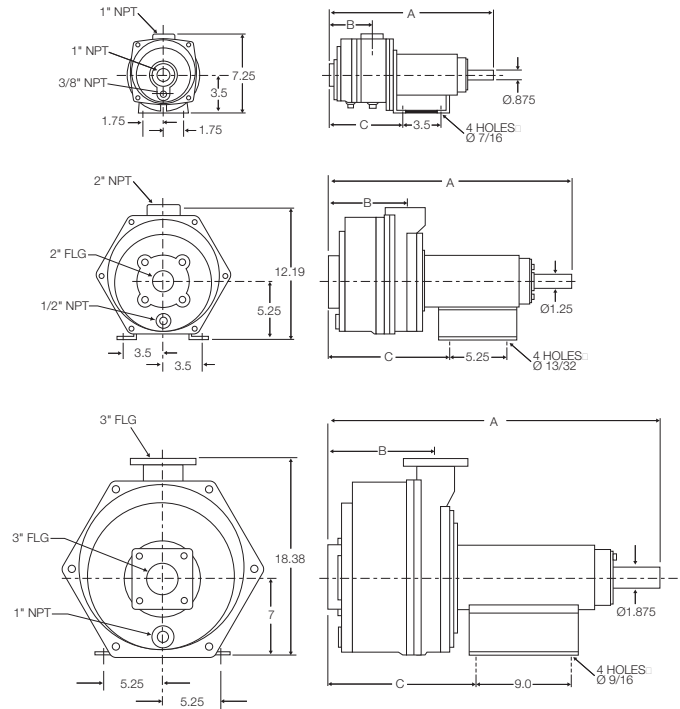

Model	A in.	B in.	C in.	WEIGHT lbs/kg
A10	14.52	3.52	6.20	42/19
A15	14.83	3.83	6.51	44/20
A20	15.60	4.60	7.28	48/22

Model	A in.	B in.	C in.	WEIGHT lbs/kg
A75	20.57	5.75	9.44	125/57
A100	21.88	7.07	10.75	130/59
A130	22.88	8.07	11.75	145/66

Model	A in.	B in.	C in.	WEIGHT lbs/kg
A200	28.81	8.31	11.88	250/114
A300	30.19	9.69	13.25	325/148

Capacity Correction Factors

Capacity Factor Using Water Other than 60°F

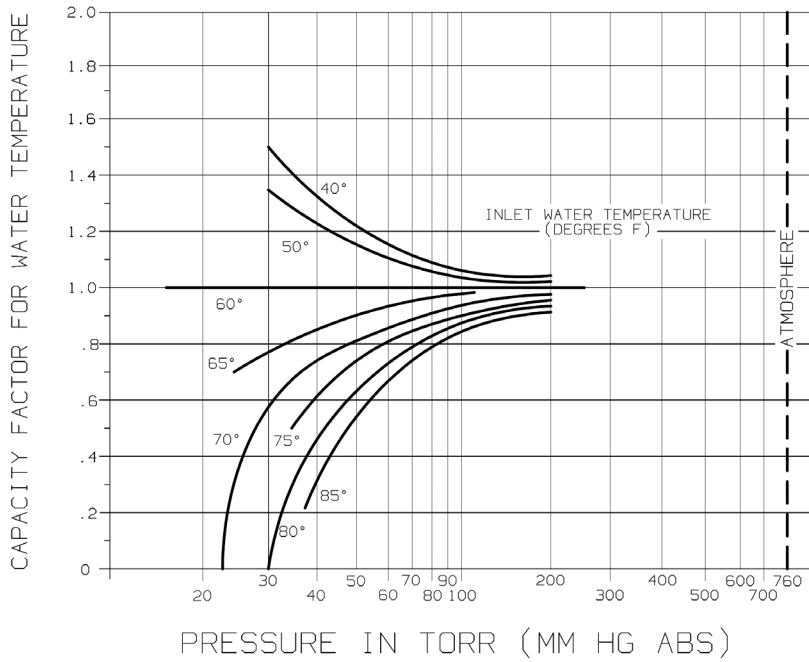

Example:

KLRC 300 is rated 250 ACFM dry air at 50 Torr using 60°F water. If incoming air is saturated at 86°F and seal water is 50°F available, the actual capacity would be:

Dry air CFM x Temperature Factor x Condensing Factor

250 x 1.11 x 1.71 = 475 CFM

Effect of Saturated Vapor on Pump Capacity

Sealing Water F°	Vacuum in Torr	Air/Water Vapor Mixture at F°					Sealing Water F°	Vacuum in Torr	Air/Water Vapor Mixture at F°				
		77	86	95	104	122			77	86	95	104	122
Factor						Factor							
50	125	1.15	1.21	1.30	1.42	2.0	77	125	1.12	1.15	1.22	1.32	1.72
	90	1.21	1.31	1.47	1.70			90	1.18	1.23	1.35	1.52	
	70	1.29	1.42	1.67	2.15			70	1.23	1.32	1.50	1.80	
	50	1.48	1.71	2.28				50	1.38	1.59	1.95		
	30	2.05											
60	125	1.18	1.23	1.30	1.48	2.0	86	125	1.11	1.15	1.20	1.31	1.68
	90	1.26	1.30	1.40	1.54			90	1.17	1.22	1.31	1.48	2.18
	70	1.32	1.41	1.56	1.90			70	1.21	1.32	1.49	1.75	
	50	1.48	1.68	2.06				50	1.35	1.55	1.90		
68	125	1.12	1.18	1.27	1.37	1.82	95	125	1.10	1.15	1.21	1.29	1.60
	90	1.19	1.27	1.39	1.57			90	1.15	1.21	1.31	1.45	2.05
	70	1.25	1.39	1.59	1.91			70	1.20	1.30	1.45	1.70	
	50	1.42	1.65	2.10				50	1.33	1.50	1.80		

Sizing & Selection | Liquid Ring Vacuum Pumps

Pump Down or Evacuation of Airtight Vessel

INCH Hg VACUUM at Sea Level	28.3	27.5	26.7	25.9	25.1	24.4	23.6	22.8	22	21.2	20.4	19.6	18.8	18.1
TORR (mm HgA)	40	60	80	100	120	140	160	180	200	220	240	260	280	300
FACTOR	2.94	2.53	2.25	2.02	1.84	1.69	1.55	1.44	1.33	1.23	1.15	1.07	0.99	0.92

Evacuate 350 ft³ volume down to 40 Torr (28.3" Hg) in 5 minutes from atmospheric pressure of 760 Torr

$$SAVG = \frac{V}{t} \ln \left(\frac{P_1}{P_2} \right) = \frac{350}{5} \ln \left(\frac{760}{40} \right) = 206 \text{ ACFM}$$

350 x 2.94 = 1029 ft³ expanded volume / 5 = 206 ACFM

Selection: KLRC 300 running at 1750 RPM

Non-Condensable Load

Air Leakage = 68 lbs/hr (1.13 lbs/min)

Inlet Vacuum = 70 Torr (27.16" Hg)

Inlet Temperature = 90°F

$$S = \frac{W}{MW} \times 359 \times \frac{P_1}{P_2} \times \frac{(460 + T_1)}{(460 + 32)} = 164 \text{ ACFM}$$

Selection: KLRC 200 running at 1750 RPM

- S = ACFM
- SAVG = Average Capacity in ACFM
- W = Mass flow rate in lbs/minute
- MW = Molecular Weight
- P₁ = Initial absolute pressure (760 Torr)
- P₂ = Required vacuum in Torr
- T₁ = Inlet temperature in F°
- V = Volume in cubic feet
- t = Time in minutes

Apply the mass flow, MW and temperature to calculate various non-condensable gas loads

Installation at Altitude

Example: Select a vacuum pump of 475 CFM capacity to operate at 20" HgV to be installed at 7000 feet above sea level

Barometric pressure at 7000 feet is 23" HgA

Vacuum at this altitude is 23" - 20" = 3" HgA

- P₁ = Corrected pressure at sea level
- P₂ = 29.92 HgA (barometric pressure at sea level)
- P_{1*} = 3" HgA (required vacuum at altitude)
- P_{2*} = 23" HgA (barometric pressure at altitude)

$$\frac{P_1}{P_2} \text{ (at sea level)} = \frac{P_{1*}}{P_{2*}} \text{ (at altitude)}$$

$$P_1 \text{ (at sea level)} = \frac{3" \text{ HgA} \times 29.92" \text{ HgA}}{23" \text{ HgA}} = 3.90" \text{ HgA OR } 26" \text{ Hg Vacuum (29.92 - 3.90)}$$



Once Through

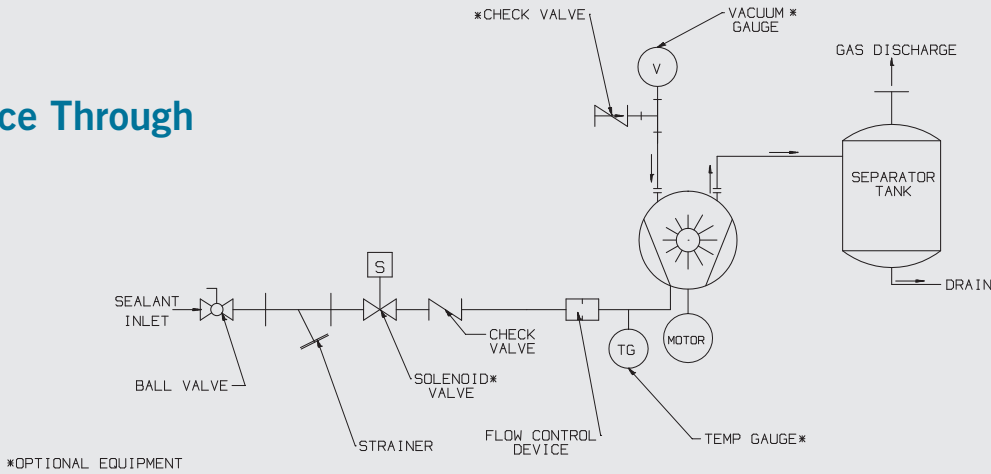

Partial Recovery

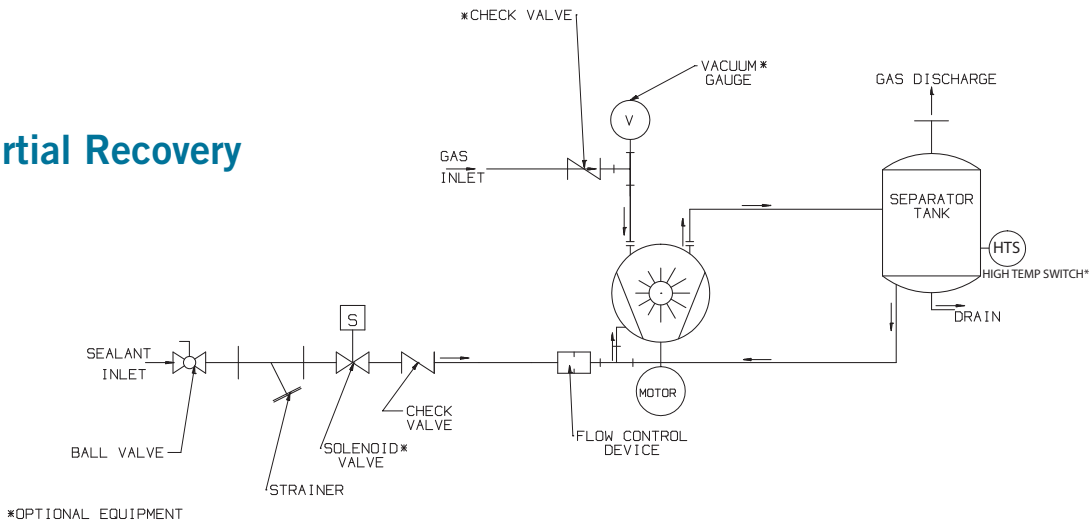

Full Recovery

(For operation above 400 Torr)

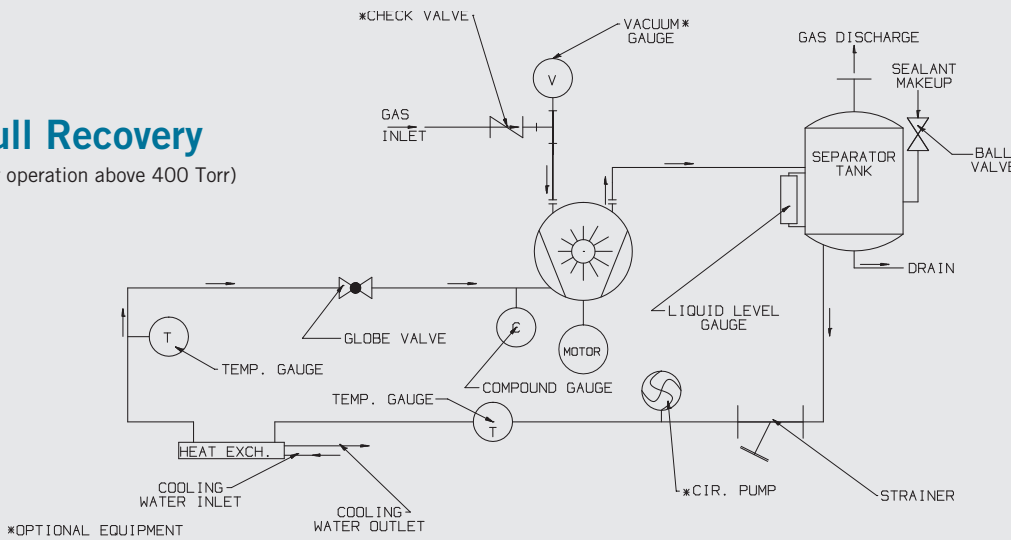



KINNEY®

CONTACT US

Kinney

4840 W. Kearney Street
Springfield, MO 65803
Phone: (800) 825-6937

LOCAL CONTACT: